

# 规格书 SPECIFICATION





风机型号 FAN MODEL **B3P560-EC188-010**

## 1. 适用范围 SCOPE

本电动机规格书适用于3相直流无刷电动机的技术规定  
 其中没有特别指明处均遵从中国国家强制性产品认证和CE认证，且满足欧盟ErP要求  
 THIS SPECIFICATION IS SPECIFIED FOR 3-PHASE DC BRUSHLESS MOTOR.  
 ITEMS EXCEPT HAVING INDICATED IN THE SPECIFICATION, ARE APPLIED TO CHINA COMPULSORY PRODUCT CERTIFICATION AND CE, AND TO MEET THE EU ErP REQUIREMENTS.

## 2. 规格 SPECIFICATIONS

项目 ITEM	内容 SPECIFICATION	备注 DESCRIPTION
电气特性 ELECTRICAL CHARACTERISTICS	电压 VOLTAGE	三相 AC380 [V] 范围: 三相AC380-480V $\triangle$ RANGE
	频率 FREQUENCY	50/60 [Hz]
	转速 SPEED	1520 $\pm$ 100 [r/min]
	功率 POWER	2770 $\pm$ 16% [W] 最大功率 3300W
	电流 CURRENT	4.4 $\pm$ 16% [A]
	最大风量 AIR FLOW	16000 MAX. [m <sup>3</sup> /h]
	噪音 NOISE	81 $\pm$ 6 [dBA]
	泄漏电流 LEAKAGE CURRENT	3.5 MAX. [mA] 测试条件 AC520V 3S TESTING CONDITIONS
	绝缘耐压 DIELECTRIC RESISTANCE	AC2200V 1S 跳闸电流10mA TRIPPING CURRENT
	绝缘电阻 INSULATION RESISTANCE	100 MIN. [M $\Omega$ ] 测试条件 DC500V TESTING CONDITIONS
	绝缘等级 INSULATION CLASS	F 级 CLASS
	控制方式 CONTROL INPUT	0-10V Vdc/PWM 见图一、二 SEE FIG. 1、2
	输出电源 OUTPUT	+10Vdc
	转速信号 TACH OUTPUT	12 PULSE/R 占空比DUTY 30%~70%
保护方式 : PROTECTED MODE	OVER-TEMPERATURE/OVER-CURRENT/LOCKED PROTECTED	

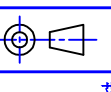
RoHS指令对应 CONFORM TO RoHS INSTRUCTIONS	角度公差 Angle Tolerance	夹角短边的长度范围 (unit mm) Classification of a shorter side of subjected angle				普通公差 General Tolerance	尺寸范围 (unit mm) Classification of basic dimension			
		X $\leq$ 10	10<X $\leq$ 50	50<X $\leq$ 120	120<X $\leq$ 400		X $\leq$ 6	6<X $\leq$ 30	30<X $\leq$ 120	120<X $\leq$ 400
	公差Tolerance	$\pm$ 1°	$\pm$ 30'	$\pm$ 20'	$\pm$ 10'	公差 Tolerance	$\pm$ 0.1	$\pm$ 0.2	$\pm$ 0.3	$\pm$ 0.5
03 '22-09-08	EC-AFL-2022-0161	参数变更		JSOZ18	材 质 MATERIAL	B3P560-EC188-010				
02 '21-09-25	EC-AFL-2021-0092	6/6页 端盖外形更新		JSOG01						
00 '21-05-18	-----	00初版		JSOG01	表 面 处 理 FINISH	风机/电机型号 MODEL				
改版 SYM	年 月 日 DATE	图面变更号 REVISION NO.	变 更 事 项 REVISIONS	设计 BY						
制 图 DRAWN	设 计 DESIGNED	检 图 CHECKED	检 印 CHECKED	比 例 SCALE	FREE	品 名 TITLE	规格书 SPECIFICATION			
				三 角 法 THIRD ANGLE PROJECTION		图 号 DWG. NO.	A112-0703-03			
艾弗洛 AFL						页 SHEET	1/6			

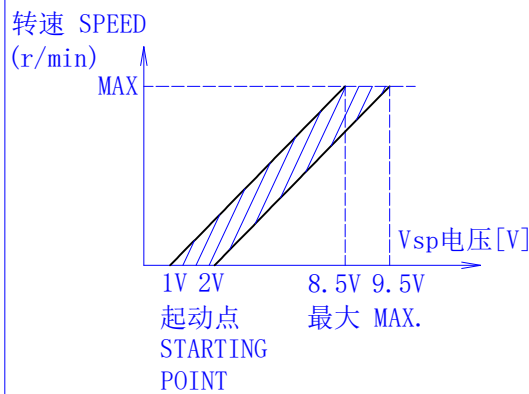

图一 FIG. 1

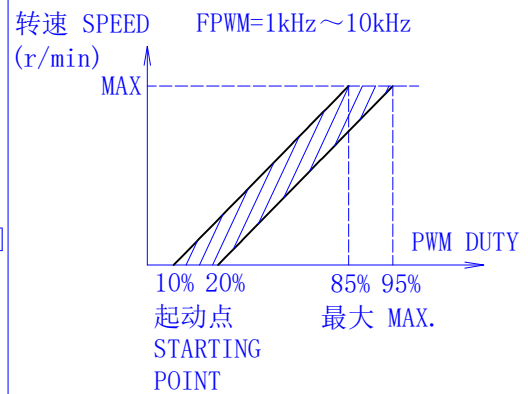

图二 FIG. 2

机械特性 MECHANICAL SPECIFICATION	外观 APPEARANCE	不能有影响商品质量的伤痕和污迹 THERE SHOULD NOT BE ANY DEFECTS AND DIRTY WHICH SPOIL GOODS VALUE	
	质量 MASS	约 APPROX 47 [Kg]	
	电机引线引拔强度 LEAD WIRE PULLED OUT STRENGTH	20 [N/根]以上 MIN.	
	寿命 L10 LIFE	40000 [h] MIN.	
	工作方式	S1	
	动平衡	G6.3	

## 3. 环境要求 ENVIRONMENTAL REQUIREMENT

保存温度 STORAGE TEMPERATURE RANGE	-40~80	[°C]	
使用·保存湿度 OPERATING, STORAGE HUMIDITY	30~95	[%]RH	无结露 NON CONDENSING
使用温度范围 OPERATING TEMPERATURE RANGE	-30~50	[°C]	

## 4. 使用注意事项 NOTE IN USE

- (1) 本电机内未设接线反接等保护线路  
SINCE THIS MOTOR HAS NO REVERSING CONNECTION
- (2) 风机的电气连接必须有合适的过流保护器以防止电流过大对产品造成损坏  
THE OVER CURRENT PROTECTOR IS NECESSARY IN CASE THE DAMAGE FROM THE OVER CURRENT
- (3) 风机运转时不可插拔风机引线插头  
PLEASE DO NOT PERFORM EXTRACTION AND INSERTION OF THE CONNECTOR UNDER REVOLUTION IRRESPECTIVE OF POWER ON AND POWER OFF
- (4) 若三相电源由接触器或继电器控制开关，风机运行时关闭三相电源，须等待1分钟或一分钟以上再开三相电源。如图：  
IF THE THREE-PHASE POWER SUPPLY IS CONTROLLED BY A CONTACTOR OR RELAY, AND THE THREE-PHASE POWER SUPPLY IS TURNED OFF WHEN THE FAN IS RUNNING, YOU MUST WAIT FOR 1 MINUTE OR MORE BEFORE TURNING ON THE THREE-PHASE POWER SUPPLY. AS SHOWN IN THE FIGURE:

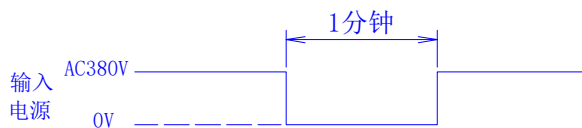

- (5) 本风机通风冷却 使用时请考虑风机周边的通风条件  
FAN CAN BE COOLED BY VENTILATION, PLEASE CONSIDER VENTILATED CONDITION AROUND THE FAN WHEN USING IT
- (6) 轴承部不可受到冲击  
DO NOT ADD SHOCK TO THE BALL BEARING
- (7) 拿取风机时不可拎风机引线 引线过度受力时内部焊接部分可能脱落  
DO NOT CARRY WITH LEAD WIRES WHEN HANDLE A FAN, IF ADD HUGE STRENGTH TO LEAD WIRES THAT THE SOLDERED PART IN FAN MAY BE SHED
- (8) 按本规格书中的规格评价风机 若工作点规格需要变更 请与本公司联系  
EVALUATE THE FAN REFER TO THIS SPECIFICATIONS. IF THE LOAD OR POWER SUPPLY VOLTAGE OF THE MOTOR SHOULD BE CHANGED, PLEASE CONTACT WITH US

## 5. 其它 OTHERS

- (1) 本款风机的知识产权属于本公司 在本款风机的使用上不会发生专利问题 应用本风机形成有关产品或方法及新的技术方案造成专利侵权 本公司不予保证 请贵公司特别注意  
THE INTELLECTUAL ASSET OF THE FAN IN THE FORM OF PATENT BELONGS TO OUR CORPORATION SO ANY PATENT PROBLEM WILL NOT BE CAUSED DURING THE ACTUAL APPLICATION. OUR CORPORATION WILL NOT BE RESPONSIBLE FOR ANY PATENT DISPUTE OR PROBLEM THAT CAUSED BY THE PRODUCT METHOD AND NEW TECHNIQUE PROJECT WHICH ARE DEVELOPED BY USING THIS FAN
- (2) 贵公司保证未经本公司许可 不得将此技术规格书泄漏给其它任何第三方  
IT SHOULD BE ASSURED THAT THIS SPECIFICATION CAN NOT BE REVEALED TO ANY THIRD PARTY WITHOUT THE CONSENT OF OUR CORPORATION
- (3) 本电机Pb Cr(VI+) Cd Hg PBB PBDE 6种物质的含有量满足RoHS指令(2002/95/EC)的要求  
MATERIALS OF MOTOR CONTAIN SIX SUBSTANCES Pb Cr(VI+) Cd Hg PBB AND PBDE, THOSE CONTENTS COMPLY WITH THE RoHS INSTRUCTION

6. P-Q曲线图 P-Q CURVES

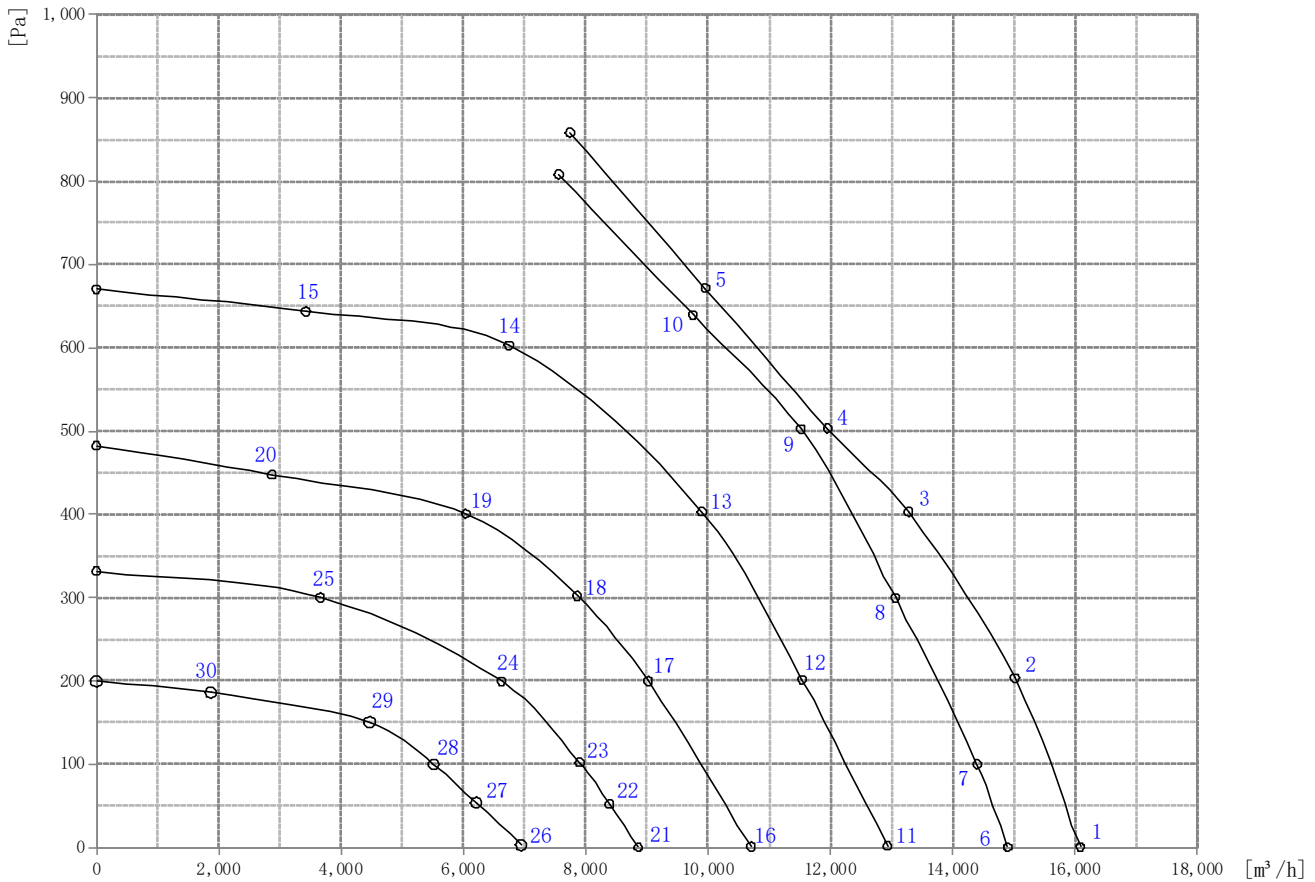

项目 ITEM	电压 VOLTAGE	频率 FREQUENCY	转速 SPEED	功率 POWER	电流 CURRENT	风量 AIRFLOW	静压 PRESSURE	Vsp	项目 ITEM	电压 VOLTAGE	频率 FREQUENCY	转速 SPEED	功率 POWER	电流 CURRENT	风量 AIRFLOW	静压 PRESSURE	转速 SPEED
单位 UNIT	[V]	[Hz]	[r/min]	[W]	[A]	[m³/h]	[Pa]	[V]	单位 UNIT	[V]	[Hz]	[r/min]	[W]	[A]	[m³/h]	[Pa]	[r/min]
1	3相380	50	1524	2768	4.44	16086	0	10	16	3相380	50	1024	858	1.52	10699	0	5.5
2	3相380	50	1526	3193	5.12	15019	203		17	3相380	50	1026	1105	1.90	9018	200	
3	3相380	50	1488	3301	5.28	13281	403		18	3相380	50	1026	1176	2.03	7859	302	
4	3相380	50	1441	3179	5.10	11957	503		19	3相380	50	1027	1164	2.01	6042	401	
5	3相380	50	1421	3141	5.04	9954	672		20	3相380	50	1026	838	1.51	2869	448	
6	3相380	50	1425	2236	3.69	14900	0	7.5	21	3相380	50	849	501	0.97	8859	0	4.5
7	3相380	50	1427	2440	4.02	14401	100		22	3相380	50	850	570	1.07	8390	52	
8	3相380	50	1418	2780	4.54	13064	300		23	3相380	50	852	623	1.15	7898	102	
9	3相380	50	1399	3001	4.88	11514	502		24	3相380	50	848	681	1.23	6623	199	
10	3相380	50	1398	2945	4.79	9751	639		25	3相380	50	850	616	1.13	3661	300	
11	3相380	50	1233	1464	2.45	12932	0	6.5	26	3相380	50	660	263	0.56	6941	0	3.5
12	3相380	50	1226	1783	2.96	11536	201		27	3相380	50	661	315	0.65	6211	54	
13	3相380	50	1232	2052	3.39	9899	403		28	3相380	50	660	333	0.68	5515	100	
14	3相380	50	1229	1954	3.25	6746	603		29	3相380	50	659	348	0.71	4468	150	
15	3相380	50	1228	1419	2.43	3426	644		30	3相380	50	660	265	0.56	1869	186	

### 7. 控制方式及应用

#### NOTES ON VARIOUS CONTROL POSSIBILITIES AND THEIR APPLICATIONS

A

B

C

D

E

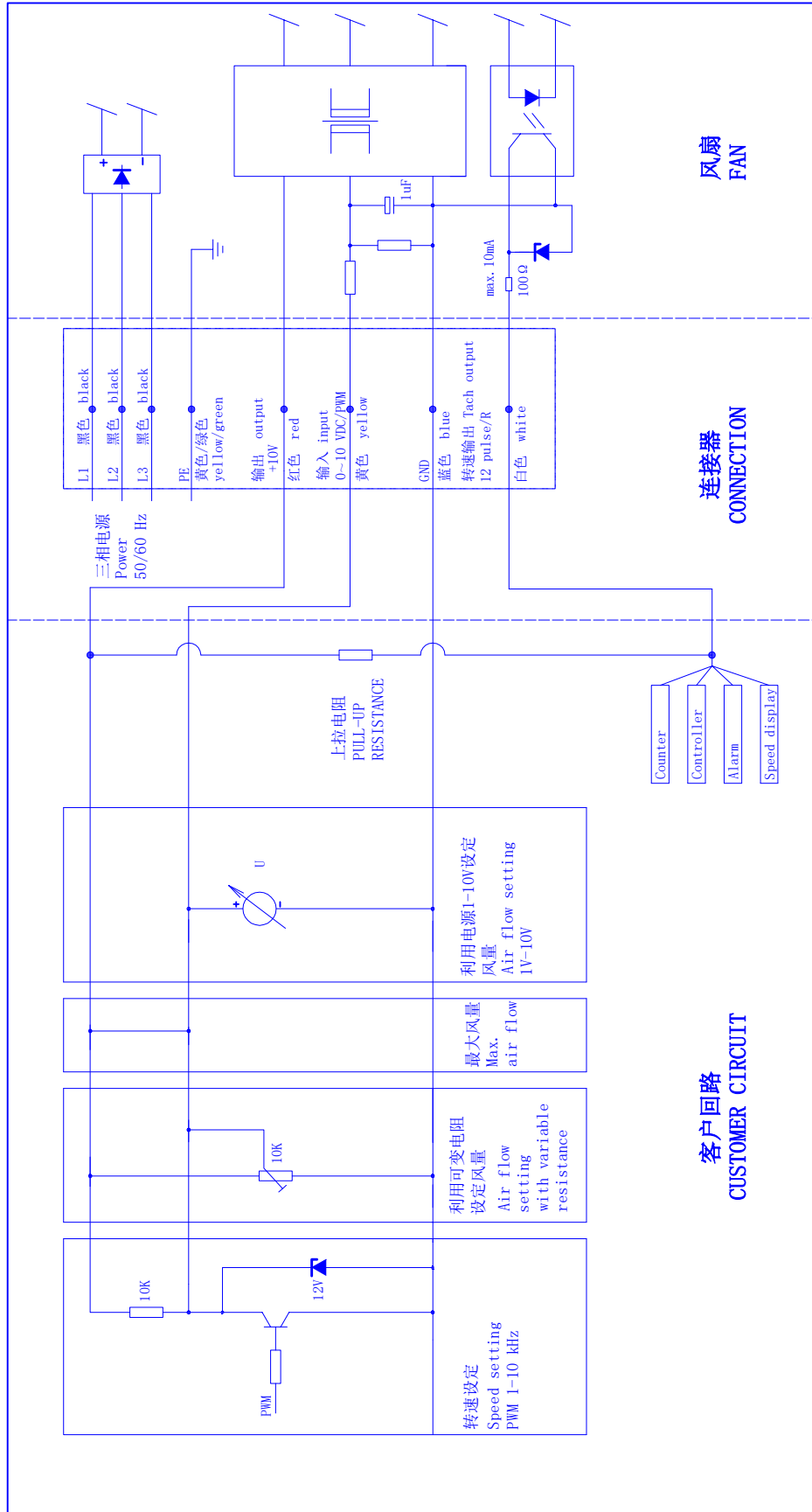

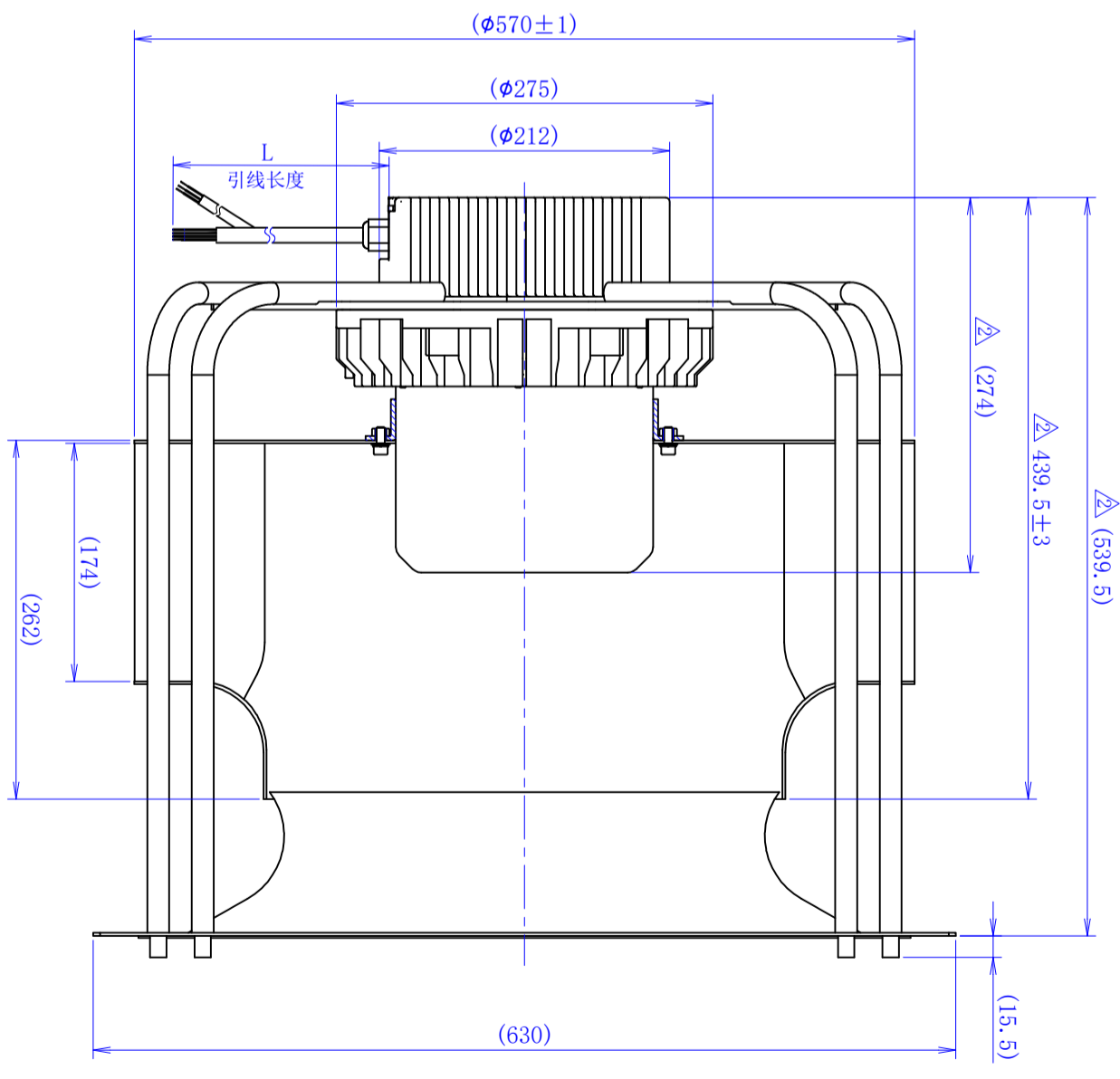
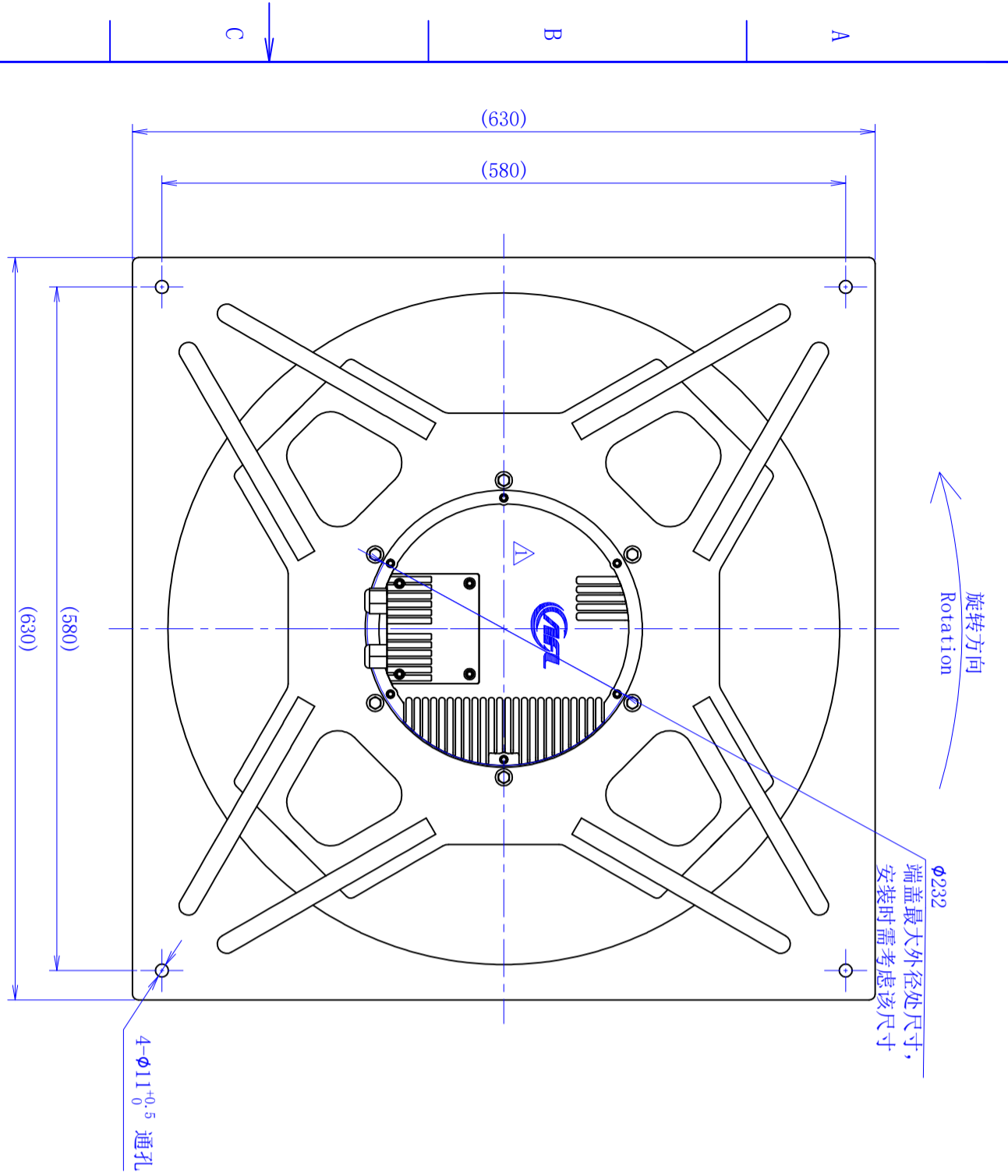

注：引线长度L根据客户需求定制(默认长度1.5米)

【引线①式样】

NO.	信号名 SIGNAL	颜色 COLOR	规格 SPEC
1	L1	黑 BLACK	AC380V/50Hz
2	L2	黑 BLACK	AC380V/50Hz
3	L3	黑 BLACK	AC380V/50Hz
4	PE	黄/绿 YELLOW/GREEN	接地

【引线②式样】

NO.	信号名 SIGNAL	颜色 COLOR	规格 SPEC
1	Vcc	红 RED	DC10V输出
2	Vsp	黄 YELLOW	0-10VDC/PWM
3	GND	蓝 BLUE	GND
4	FG	白 WHITE	12 Pulse/R

【铭牌一内容】

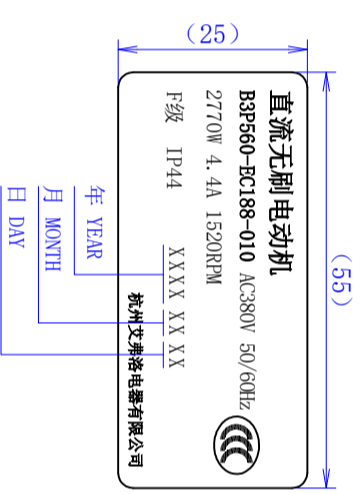

【铭牌二内容】

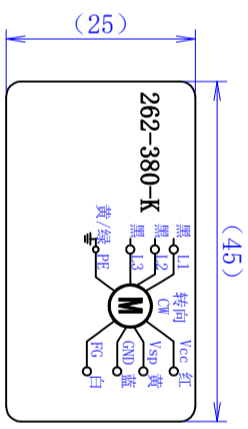

【LABEL ONE CONTENTS】

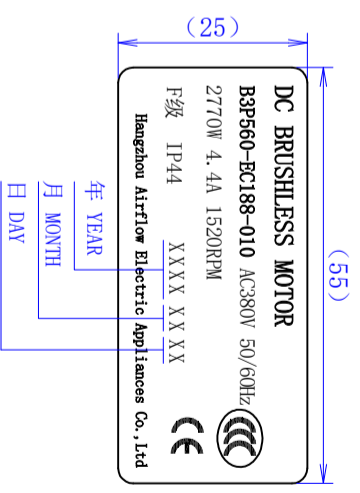

【LABEL TWO CONTENTS】

