

规格书 SPECIFICATION

标准品
STANDARD FAN

风机型号 FAN MODEL **B3P450-EC102-100**

1. 适用范围 SCOPE

本电动机规格书适用于3相直流无刷电动机的技术规定
 其中没有特别指明处均遵从中国国家强制性产品认证和CE认证，且满足欧盟ErP要求
 THIS SPECIFICATION IS SPECIFIED FOR 3-PHASE DC BRUSHLESS MOTOR.
 ITEMS EXCEPT HAVING INDICATED IN THE SPECIFICATION, ARE APPLIED TO CHINA COMPULSORY PRODUCT CERTIFICATION AND CE, AND TO MEET THE EU ErP REQUIREMENTS.

2. 规格 SPECIFICATIONS

项目 ITEM	内容 SPECIFICATION			备注 DESCRIPTION
电气特性 ELECTRICAL CHARACTERISTICS	电压 VOLTAGE	AC220	[V]	范围: AC200-277V RANGE
	频率 FREQUENCY	50/60	[Hz]	
	转速 SPEED	1100 ±10%	[r/min]	
	功率 POWER	260 ±16%	[W]	
	电流 CURRENT	1.2 ±16%	[A]	
	最大风量 AIR FLOW	4600 MAX.	[m³/h]	
	噪音 NOISE	70±6	[dBA]	
	泄漏电流 LEAKAGE CURRENT	3.5 MAX.	[mA]	测试条件 AC260V 3S TESTING CONDITIONS
	绝缘耐压 DIELECTRIC RESISTANCE	AC1800V		1S 跳闸电流10mA TRIPPING CURRENT
	绝缘等级 INSULATION CLASS	B 级 CLASS		
	控制方式 CONTROL INPUT	0-10V Vdc/PWM		见图一、二 SEE FIG. 1、2
	输出电源 OUTPUT	+10Vdc		
	转速信号 TACH OUTPUT	12 PULSE/R		占空比DUTY 30%~70%须在+10V与TACH OUTPUT间连接10KΩ上拉电阻/IT NEEDS 10KΩ PULL-UP RESISTANCE BETWEEN +10V LINE AND TACH OUTPUT LINE
	保护方式 : PROTECTED MODE	OVER-TEMPERATURE/OVER-CURRENT/LOCKED PROTECTED		

RoHS指令对应 CONFORM TO RoHS INSTRUCTIONS	角度公差 Angle Tolerance	夹角短边的长度范围 (unit mm) Classification of a shorter side of subjected angle				普通公差 General Tolerance	尺寸范围 (unit mm) Classification of basic dimension			
	公差 Tolerance	X≤10	10<X≤50	50<X≤120	120<X≤400	公差 Tolerance	X≤6	6<X≤30	30<X≤120	120<X≤400
		±1°	±30'	±20'	±10'		±0.1	±0.2	±0.3	±0.5

00	'19-11-09	-----	00初版	JS0G01	材质 MATERIAL	-----	B3P450-EC102-100
改版 SYM	年月日 DATE	图面变更号 REVISION NO.	变更事项 REVISIONS	设计 BY	表面处理 FINISH	-----	
				风机/电机型号 MODEL			

制图 DRAWN	设计 DESIGNED	检图 CHECKED	检印 CHECKED	比例 SCALE	FREE	品名 TITLE	规格书 SPECIFICATION	
艾弗洛 '19-11-09 JS0G01	艾弗洛 '19-11-09 JS0G01	艾弗洛 '19-11-09 JS9S02	艾弗洛 '19-11-09 JS9S02	三角法 THIRD ANGLE PROJECTION		图号 DWG. NO.	A112-0468-00	
杭州艾弗洛电器有限公司 HANGZHOU AIRFLOW ELECTRIC APPLIANCES CO., LTD.							页 SHEET	1/6

1

2

3

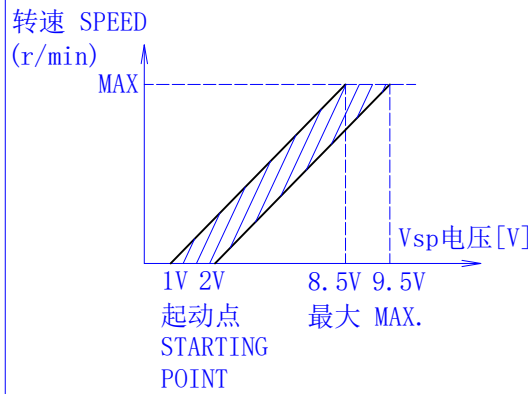

图一 FIG. 1

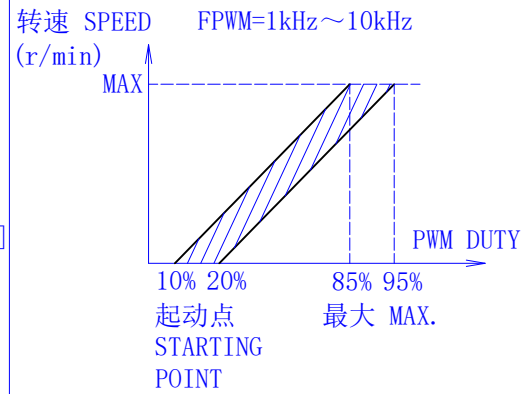

图二 FIG. 2

外观 APPEARANCE

不能有影响商品质量的伤痕和污迹
THERE SHOULD NOT BE ANY DEFECTS AND DIRTY WHICH
SPOIL GOODS VALUE

质量 MASS

约 APPROX 5.5 [Kg]

机械特性
MECHANICAL
SPECIFICATION电机引线引拔强度
LEAD WIRE PULLED
OUT STRENGTH

20 [N/根]以上 MIN.

寿命 L10
LIFE

40000 [h] MIN.

3. 环境要求 ENVIRONMENTAL REQUIREMENT

保存温度 STORAGE TEMPERATURE RANGE	-25~60 [°C]	
使用·保存湿度 OPERATING, STORAGE HUMIDITY	30~95 [%]RH	无结露 NON CONDENSING
使用温度范围 OPERATING TEMPERATURE RANGE	-20~60 [°C]	
	IC散热 HEAT SINK OF IC	115[°C]以下 MAX
	其他电子部品 OTHER ELECTRONIC PARTS	85[°C]以下 MAX
	轴承 BALL BEARING	80[°C]以下 MAX
	卷线 COIL	120[°C]以下 MAX

4. 使用注意事项 NOTE IN USE

- | | |
|---|--|
| A | (1) 本电机内未设接线反接等保护线路
SINCE THIS MOTOR HAS NO REVERSING CONNECTION |
| | (2) 起动时电流过大会损坏电机 请防止电流峰值超过2.5A
TO PREVENT MOTOR DAMAGED BY OVER STARTING CURRENT, THE PEAK CURRENT CAN NOT EXCEED 2.5A |
| | (3) 风机运转时不可插拔风机引线插头
PLEASE DO NOT PERFORM EXTRACTION AND INSERTION OF THE CONNECTOR UNDER REVOLUTION
IRRESPECTIVE OF POWER ON AND POWER OFF |
| | (4) 本风机通风冷却 使用时请考虑风机周边的通风条件
FAN CAN BE COOLED BY VENTILATION, PLEASE CONSIDER VENTILATED CONDITION AROUND THE
FAN WHEN USING IT |
| | (5) 轴承部不可受到冲击
DO NOT ADD SHOCK TO THE BALL BEARING |
| | (6) 拿取风机时不可拎风机引线 引线过度受力时内部焊接部分可能脱落
DO NOT CARRY WITH LEAD WIRES WHEN HANDLE A FAN, IF ADD HUGE STRENGTH TO LEAD WIRES
THAT THE SOLDERED PART IN FAN MAY BE SHED |
| | (7) 按本规格书中的规格评价风机 若工作点规格需要变更 请与本公司联系
EVALUATE THE FAN REFER TO THIS SPECIFICATIONS. IF THE LOAD OR POWER SUPPLY VOLTAGE
OF THE MOTOR SHOULD BE CHANGED, PLEASE CONTACT WITH US |

5. 其它 OTHERS

- | | |
|---|--|
| C | (1) 本款风机的知识产权属于本公司 在本款风机的使用上不会发生专利问题 应用本风机形成有关产品
或方法及新的技术方案造成专利侵权 本公司不予保证 请贵公司特别注意
THE INTELLECTUAL ASSET OF THE FAN IN THE FORM OF PATENT BELONGS TO OUR CORPORATION
SO ANY PATENT PROBLEM WILL NOT BE CAUSED DURING THE ACTUAL APPLICATION. OUR CORPORATION
WILL NOT BE RESPONSIBLE FOR ANY PATENT DISPUTE OR PROBLEM THAT CAUSED BY THE PRODUCT
METHOD AND NEW TECHNIQUE PROJECT WHICH ARE DEVELOPED BY USING THIS FAN |
| | (2) 贵公司保证未经本公司许可 不得将此技术规格书泄漏给其它任何第三方
IT SHOULD BE ASSURED THAT THIS SPECIFICATION CAN NOT BE REVEALED TO ANY THIRD PARTY
WITHOUT THE CONSENT OF OUR CORPORATION |
| | (3) 本电机Pb Cr(VI+) Cd Hg PBB PBDE 6种物质的含有量满足RoHS指令(2002/95/EC)的要求
MATERIALS OF MOTOR CONTAIN SIX SUBSTANCES Pb Cr(VI+) Cd Hg PBB AND PBDE, THOSE CONTENTS
COMPLY WITH THE RoHS INSTRUCTION |

6. P-Q曲线图 P-Q CURVES

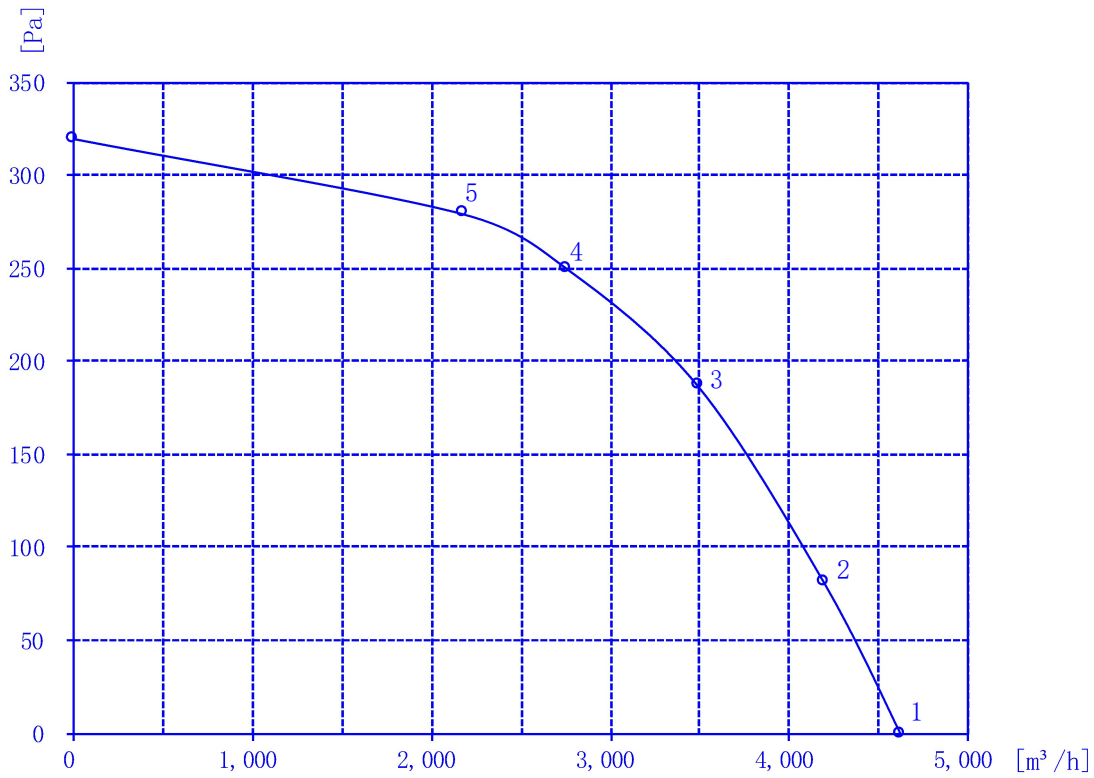

项目 ITEM	电压 VOLTAGE	频率 FREQUENCY	转速 SPEED	功率 POWER
单位 UNIT	[V]	[Hz]	[r/min]	[W]
1	220	50	1102	278
2	220	50	1105	345
3	220	50	1110	405
4	220	50	1083	400
5	220	50	1083	378

1

2

3

7. 控制方式及应用

NOTES ON VARIOUS CONTROL POSSIBILITIES AND THEIR APPLICATIONS

A

B

C

D

E

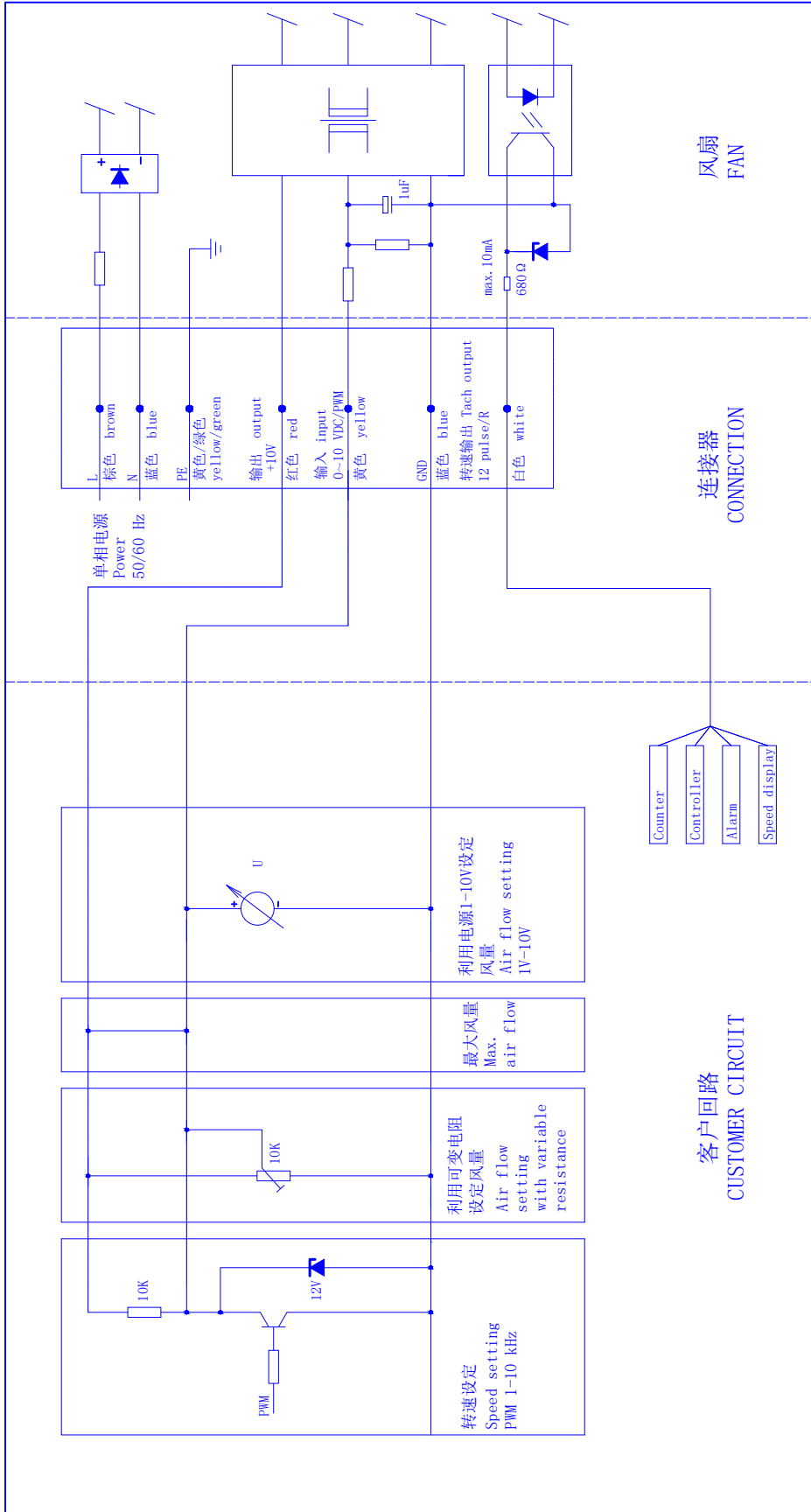

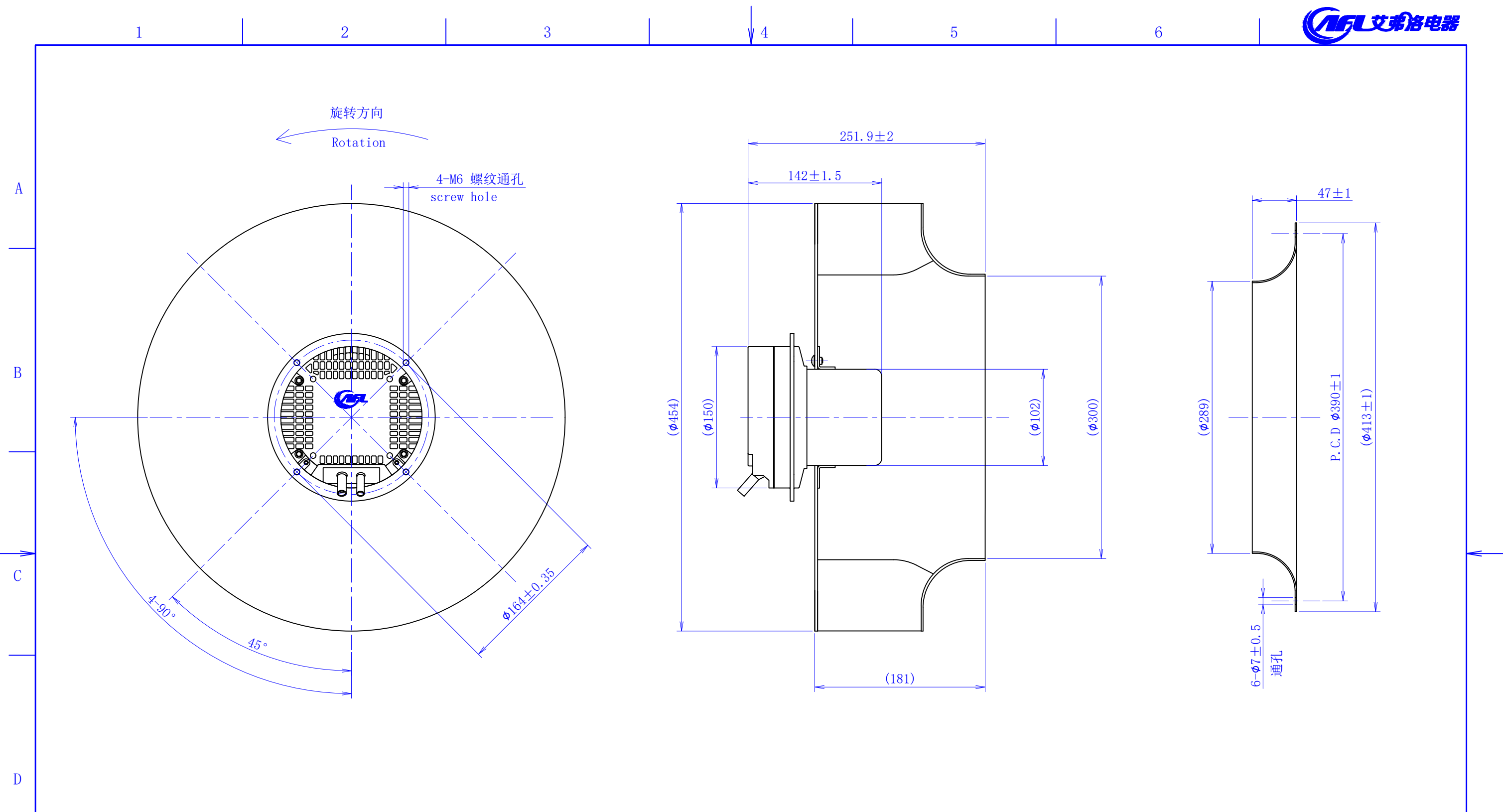

【引线①式样】

【LEAD WIRES ASS'Y ①】

电线 WIRES: 3*AWG18

NO.	信号名 SIGNAL	颜色 COLOR	规格 SPEC
1	L	棕 BROWN	AC220V/50Hz
2	N	蓝 BLUE	AC220V/50Hz
3	PE	黄/绿 YELLOW/GREEN	接地 EARTH

【引线②式样】

【LEAD WIRES ASS'Y ②】

电线 WIRES: 4*AWG22

NO.	信号名 SIGNAL	颜色 COLOR	规格 SPEC
1	GND	红 RED	DC10V输出
2	Vsp	黄 YELLOW	0-10V/PWM
3	Vcc	蓝 BLUE	GND
4	FG	白 WHITE	12 Pulse/R

【铭牌一内容】

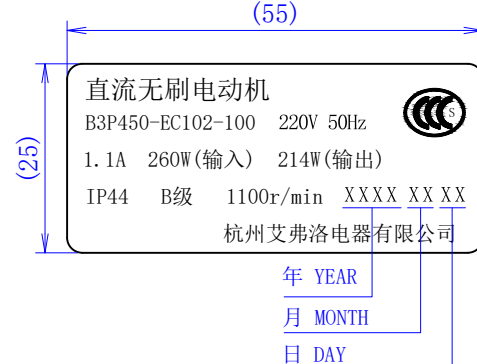

【铭牌二内容】

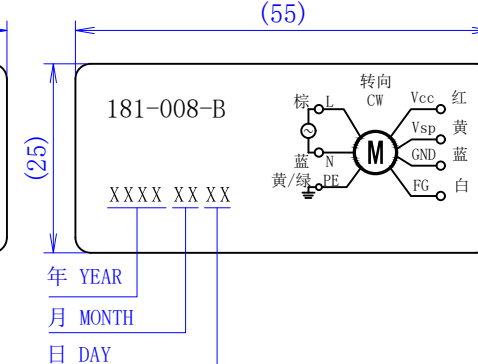

【LABEL FIRST CONTENTS】

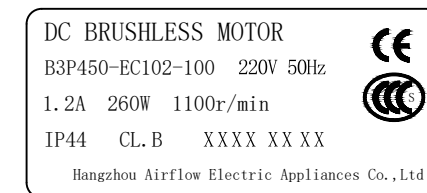

【LABEL SECOND CONTENTS】

